



WALKER FILTRATION

The ultimate filtration & drying technology

ALPHA

Compressed Air Filter Range

Exceptional engineering.
Improved performance.
Customer focus.



ALPHA SERIES

Introducing the New Alpha Series, Walker Filtration's most advanced filter to date

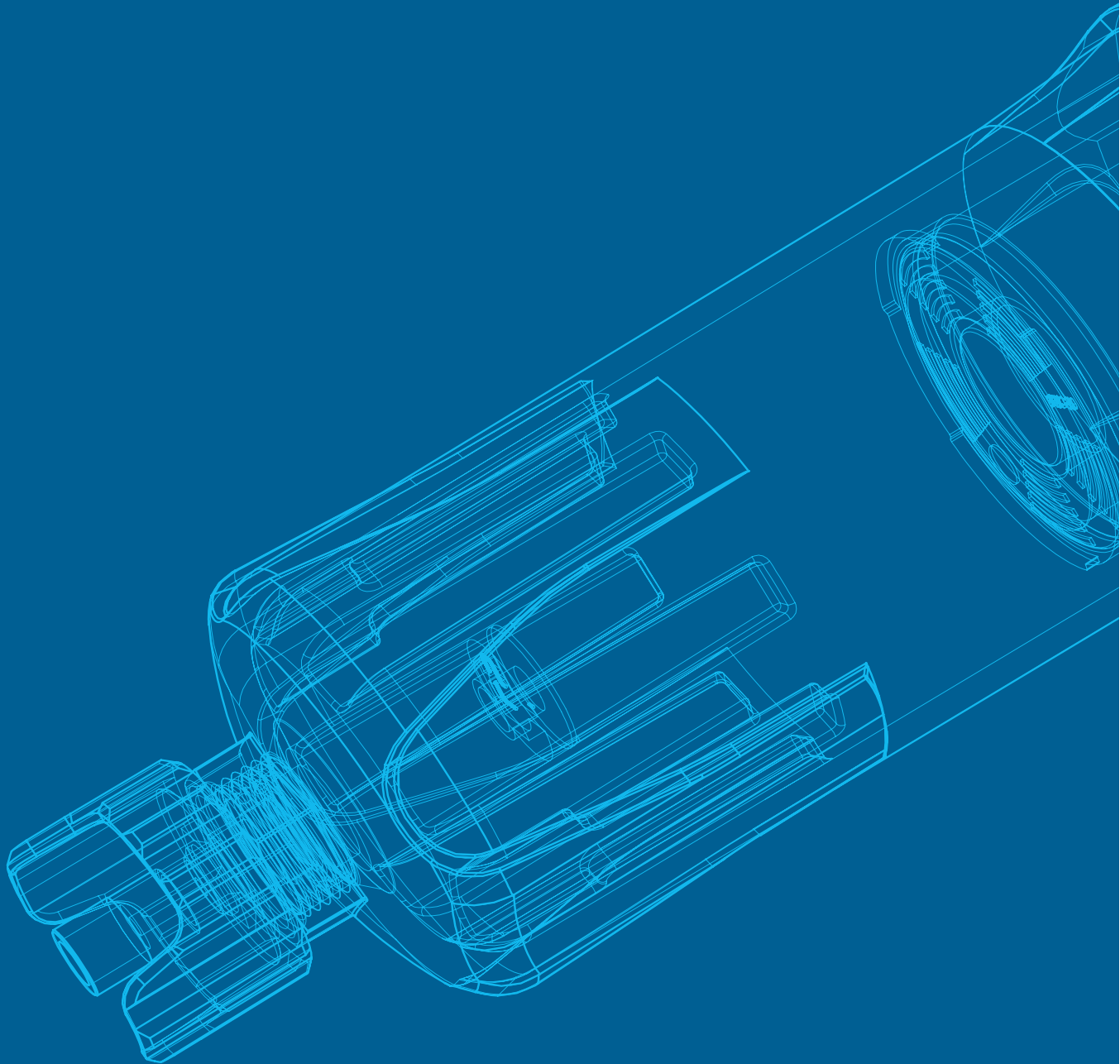

Where engineering excellence meets innovative filtration design



To our customers, Walker Filtration stands for innovation, quality and exceptional customer service.

Our promise is to provide high performing, energy efficient and cost effective compressed air filtration solutions that meet the exacting standards set out in ISO 8573-1: 2010.

Our commitment to exceptional design, along with a proven track record of engineering excellence, has allowed us to remain at the forefront of compressed air and gas filtration and drying. We understand that our long-term success depends on our ability to deliver product of exceptional quality and continuously innovate,

which is why our clients and customers have put their complete trust in our product for over 30 years.

Central to our business is providing tailored solutions to our customers' challenging compressed air and gas problems worldwide.

As partners of choice we work hard to understand our customer needs. Whether our customers require high quality, reliable and economical replacement elements, or a unique custom built solution tailored to their needs.

Walker Filtration delivers the ultimate filtration and drying solution every time.

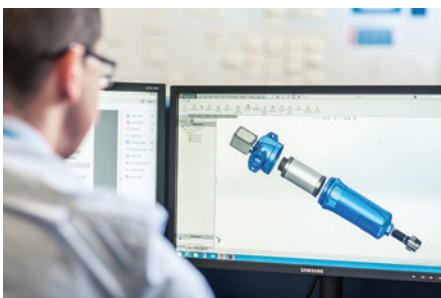



Walker Filtration's New Alpha Series is market leading in the industry today.

With energy efficiency and low total cost of ownership at the very forefront of the design, the New Alpha surpasses its predecessors and conventional filters in the market place, proving to be Walker Filtration's most advanced filter yet.

The expertly engineered all New Alpha Series not only achieves the highest air purity standards in line with ISO 8573-1: 2010, it also incorporates the latest in filtration technology. The new filter housing has been redesigned to reduce differential pressure loss which, when combined with the new element design, significantly improves air flow and performance, making the New Alpha one of the most energy efficient filter

housings available. Walker Filtration's Design Engineers set out to create a forward thinking product range that is as dynamic as the applications they are used in.

With a range that incorporates Water Separators, Particulate Filters, Coalescing Filters, and Vapour Filters, all of which are available in a wide range of port sizes suitable for installation worldwide, they have done just that.





Flow-Optimised Design

- Improved air flow characteristics
- Reduced energy consumption
- Reduced cost of ownership

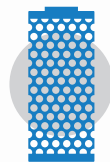

Increased Performance

- Significantly reduced differential pressure <math>< 125 \text{ mbar}</math>
- Up to 20.7 barg (300 psig) maximum working pressure
- Exceptional oil aerosol and particulate removal

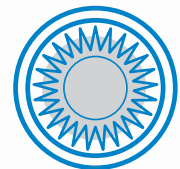

NEW Filtration Technology

- NEW deep pleated media
- NEW housing design for flexible installation and simplified serviceability
- NEW externally accessible drain

Introducing the New Alpha. The Ultimate in Filtration Performance.

The New Alpha Series provides a comprehensive range that protects downstream equipment from contaminants found in compressed air. With a maximum operating temperature of 120°C (248°F) and improved maximum operating pressures of up to 20.7 barg, meaning that whatever your filtration requirement, we have a solution.

Features & Benefits

Flexible Installation

Available in 1/8" to 3" threaded BSPP (Rp), BSPT and NPT port sizes, with flow rates of 6 – 1500 scfm (10 – 2550 Nm³/h). Maximum working temperature 120°C (248°F), maximum operating pressure of up to 20.7 barg (300 psig).

Modular Filter

Low cost connecting kits and new filter head design enables easy and simple close coupling assembly to accommodate a wide range of application requirements.

Flow-optimised Design

Advanced filter design to optimise flow capabilities, significantly reducing differential pressure loss and therefore increasing energy efficiency.

Product Safety in Mind

Guaranteed safe housing closure with single-start thread and fixed thread engagement stop to prevent over tightening. Lock indication arrows assure effective sealing.

Reliable Filtration Performance

Tested and validated in accordance with ISO 12500-1 & ISO 8573-1: 2010, Walker Filtration filter housings and elements are manufactured using only the highest quality materials to provide optimum performance and improved efficiencies.

Colour Coded Elements

Corrosion resistant colour coded end caps for easy and accurate filtration grade identification.





Robust Design & EP Corrosion Protection

The new range offers corrosion resistance and salt spray testing to ISO 9227: 2012. Durable and hard wearing EP coating on both internal and external faces of the filter housing.

Market Leading Performance

Introducing new deep pleated media technology across New Alpha elements; a step change in performance, combined with a custom engineered anti re-entrainment layer for exceptional oil coalescence, ensures low total cost of ownership.

New Externally Accessible Drain

Unique, externally accessible automatic drain fitted to Filter models A3052 to A3303. The drain is supplied as standard with a plastic drain shield cover.

Simplified Serviceability

Designed with servicing and maintenance in mind, the new profiled bowl design and hexagonal spanner locator coupled with the internal unique push fit element ensures a simple, quick and reliable process.

Differential Pressure Equipment

Supplied to aid with servicing of filter elements (except A3011, A3021).

Unrivalled Performance

Available in five filtration grades (25 - 0.01 micron), New Alpha elements ensure significant energy savings with guaranteed class leading performance; X1 and XA grade across the range provide a saturated differential pressure of less than or equal to 125mbar.



New Filtration technology

Walker Filtration utilises deep pleated media to deliver market leading filtration performance. The new forward thinking design delivers exceptional results in both oil aerosol removal and particulate retention; significantly reducing differential pressure and energy consumption for low operational lifetime costs. Engineered to deliver a step change in performance, the New Alpha element optimises filtration efficiencies and produces compressed

air in line with the highest standards of air purity, meeting the quality classes specified in ISO 8573-1: 2010.

To ensure optimal performance and low cost is maintained, Alpha filter elements should be replaced with Walker Filtration original parts every 12 months/8000 hours (whichever comes first). Activated carbon filter elements should be replaced every 6 months/1000 hours (whichever comes first).

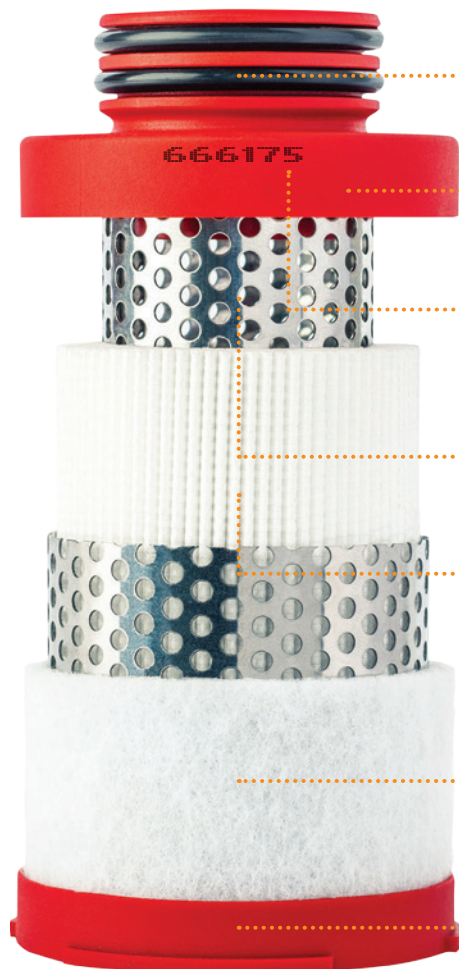
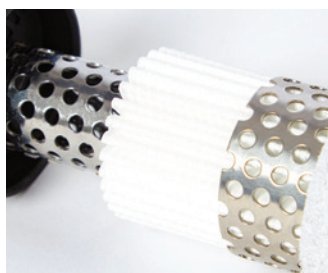

Features & Benefits

Push Fit Walker Filtration Elements ensure perfect sealing within the filter housing and assist with easy removal

Corrosion resistant end caps Injection moulded from glass filled nylon for added durability

Full traceability is provided by ink jet marking manufacturing batch codes on every filter element complying with our ISO 9001 manufacturing process

High quality stainless steel cylinders provide corrosion resistance and deliver strength and stability to the element

Custom engineered Hydrophobic & Oleophobic Borosilicate media specifically developed to deliver consistently low pressure drop, combined with pleated element construction for high dirt holding capacity and an increased filtration surface area

Custom outer drainage layer prevents oil carryover and improves coalescence performance

Unique Walker Filtration Element end cap colour coding system for quick and simple grade identification

Performance Assured

For more than 30 Years, Walker Filtration has built a reputation of high quality, well-engineered filtration and drying products. Founded on sound engineering principles, we continually invest in technology and expertise to stay at the leading edge of innovation. It is this investment, combined with the extensive knowledge of our engineering and technical team, which has allowed us to achieve

the dramatic improvements in performance that our New Alpha Series delivers.

The New Alpha's optimised performance has been extensively proven throughout the research and development phase using our in house test facilities, finite element analysis and computational fluid dynamics.



Filter Housing Design

The ISO 8573 group of International Standards is used for the classification of compressed air.

- ✓ 1000 hour neutral salt spray test for corrosion to ISO 9227: 2006
- ✓ Burst pressure tested in excess of 100 barg for a 5:1 safety factor
- ✓ Housings are pressure decay tested before despatch. Fine filters are 100% aerosol integrity tested

Element Technology

The New Alpha Series is available in a complete range of contaminant removal grades designed to meet the compressed air purity requirements throughout industry.

- ✓ **ISO 8573-1: 2010** – Compressed air purity standard
- ✓ **ISO 12500 Series** – International standard for compressed air filter testing

Independent Validation

Walker Filtration's filter housings are manufactured and tested to meet the requirements of the Pressure Equipment Directive (2014/68/EU).

- ✓ **Pressure Equipment Directive 2014/68/EU**
Lloyd's Register EMEA – Notified Body No. 0038
71 Fenchurch Street, London, EC3M 4BS
- ✓ **ISO 9001 Quality Systems – LRQ0930553**
Lloyd's Register EMEA – Notified Body No. 0038
1 Trinity Park, Bickenhill Lane, Birmingham, B37 7ES, United Kingdom



Extensive Filter Range

The new range of threaded filters is available from 1/8" to 3" with flow rates from 6 – 1500 scfm (10 – 2550 Nm³/hr) with a maximum operating pressure of 20.7 barg (300 psig).

With the New Alpha Series Walker Filtration have designed the product range to provide the greatest flexibility and best in class performance. The Alpha Series includes single and duplex filters, fabricated filter housings, and a comprehensive range of elements suitable for a wide range of applications.



Water Separators

The New Alpha Water Separator combines proven Alpha centrifugal technology with a new forward thinking housing design to deliver market leading water removal efficiencies – eliminating 99% bulk water and guaranteeing continuously low differential pressure.

Compressed Air & Gas Filters

Our range of single and duplex air and gas filters come in five filtration grades (Activated Carbon and 25 to 0.01 micron), with silicone free options and specialist LABSfrei and ATEX capability.

Dust Filters

Available in all grades, for installations downstream of regenerative compressed air and gas dryers.

Vacuum Pump Protection

Our range of filters offer high efficiency and optimum contaminant removal for vacuum pump protection.

Vacuum Pump Exhaust

Two types of vacuum pump exhaust filters are available to remove oil mist from oil injected vacuum pumps.

Medical Sterile

This specialist range of filters is designed to meet the very specific needs for medical compressed air plants.

New PRO XF Flanged Filters

Modular filtration concept which can be easily multi-banked together – ideal for larger flows from 900 – 3000 scfm (1529 – 5097 Nm³/hr).

Fabricated Flanged Filters

The ideal solution for larger flow applications, guaranteeing the highest levels of air quality from 3824 – 15000 scfm (8720 – 25500 Nm³/hr). Walker Filtration can supply flanged filters in two formats - PRO XF Flanged Filters and Conventional Fabricated Vessels.



Accessories

To accompany our standard range, we supply a comprehensive range of spares and accessories. For more information on accessories please see Walker Filtration Product Range and Price Guide.



For more information on our full product range, please contact your nearest sales team or visit www.walkerfiltration.com

We Provide Solutions for Your Industry

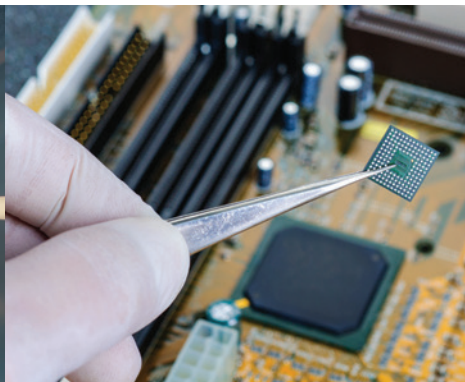

In any compressed air system, impurities are inevitable. Dust, dirt, water and oil contaminants can reduce air quality and significantly affect system efficiency.

Inadequate or incorrect filtration can negatively impact performance and end-use equipment, and cause

potential costly system downtime. With over 30 years' experience Walker Filtration has built up extensive industry know-how that supports our customers with tailored solutions to meet the varying demands and standards required by industries in delivering high performance compressed air.

With enhanced housing features and market leading element performance the New Alpha Series offers a comprehensive range of products that deliver up to 99.999% filtration efficiencies for particulates as small as 0.01 microns.



General Industry



Vacuum Packaging



Food Production



Paint Spraying



Beverage & Breweries



Laboratories



Power Generation



Automotive



Military



Welding



Medical

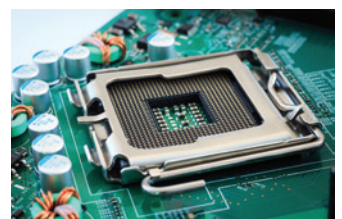

Electronics

Tailored Solutions for



At Walker Filtration, we are proud of our exceptional in-house design capabilities offering customised solutions that meet exacting standard set by our customers.

We have designed, developed and delivered many unique and successful OEM products to industry leaders across the world.

With the expertise of our dedicated design team, and supported by our manufacturing capability that allows flexibility to support customers with complex requirements. We work in complete collaboration with our OEM customers from initial concept designs and engineering, through testing and validation, to branding and aftermarket support. Our focus and dedication is straightforward – we enjoy working with our customers, offering competent advice and sound engineering, to help achieve the specific solutions required.

CONSULTATION
& DEVELOPMENT



TESTING &
APPROVAL



MANUFACTURE
& DELIVERY

Intelligent Branding

We work with OEM customers to provide options to customise and brand products and packaging, along with a range of supporting marketing materials, to achieve maximum brand identity and recognition. All aspects of the product are considered, including language support, unique part numbers and transport details.

Performance and Validation

For complete peace of mind our OEM developments are extensively tested to the highest standards; assuring complete product quality and performance. Throughout the entire process, excellent levels of customer service are at the heart of everything we do.

Technical Specification

	Filter Model	Pipe Size	Flow Rate		Dimension (mm)				Weight (KG) Approx.	Element Model
			Nm ³ /h	SCFM	A	B	C	D		
Water Separators	A3011 WS	1/8	10	6	50	17	157	60	0.25	N/A
	A3021 WS	1/4	25	15	50	17	157	60	0.25	N/A
	A3022 WS	1/4	42	25	70	24	231	70	0.6	N/A
	A3031 WS	3/8	54	32	70	24	231	70	0.6	N/A
	A3051 WS	1/2	85	50	70	24	231	70	0.6	N/A
	A3052 WS	1/2	119	70	127	32	285	80	1.7	N/A
	A3071 WS	3/4	144	85	127	32	285	80	1.7	N/A
	A3101 WS	1	229	135	127	32	285	80	1.7	N/A
	A3122 WS	1 1/4	476	280	170	53	508	100	4.9	N/A
	A3151 WS	1 1/2	680	400	170	53	508	100	4.9	N/A
	A3201 WS	2	765	450	170	53	508	100	4.9	N/A
	A3251 WS	2 1/2	1444	850	220	70	450	100	8	N/A
A3301 WS	3	2549	1500	220	70	450	100	8	N/A	
Coalescing & Particulate	A3011 (grade)	1/8	10	6	50	17	157	60	0.25	E30306 (grade)
	A3021 (grade)	1/4	25	15	50	17	157	60	0.25	E30306 (grade)
	A3022 (grade)	1/4	42	25	70	24	231	70	0.6	E30408 (grade)
	A3031 (grade)	3/8	54	32	70	24	231	70	0.6	E30408 (grade)
	A3051 (grade)	1/2	85	50	70	24	231	70	0.6	E30412 (grade)
	A3052 (grade)	1/2	119	70	127	32	285	80	1.7	E30612 (grade)
	A3071 (grade)	3/4	144	85	127	32	285	80	1.7	E30612 (grade)
	A3101 (grade)	1	178	105	127	32	285	80	1.7	E30612 (grade)
	A3072 (grade)	3/4	212	125	127	32	371	80	2	E30621 (grade)
	A3102 (grade)	1	297	175	127	32	371	80	2	E30621 (grade)
	A3122 (grade)	1 1/4	476	280	170	53	508	100	4.9	E30831 (grade)
	A3151 (grade)	1 1/2	680	400	170	53	508	100	4.9	E30831 (grade)
	A3201 (grade)	2	765	450	170	53	508	100	4.9	E30831 (grade)
	A3202 (grade)	2	1189	700	170	53	708	100	5.5	E30850 (grade)
	A3251 (grade)	2 1/2	1444	850	220	70	736	100	10.5	E31140 (grade)
A3301 (grade)	3	1529	900	220	70	736	100	10.5	E31140 (grade)	
A3302 (grade)	3	2125	1250	220	70	857	100	11.5	E31160 (grade)	
A3303 (grade)	3	2550	1500	220	70	1005	100	12.5	E31175 (grade)	
Duplex Filters	D3028	1/4	42	25	70	199	204	70	1	E30408 DXA / DAC
	D3038	3/8	54	32	70	199	204	70	1	E30408 DXA / DAC
	D3058	1/2	85	50	70	199	204	70	1.1	E30412 DXA / DAC
	D3059	1/2	119	70	100	236	240	80	2.3	E30613 DXA / DAC
	D3078	3/4	144	85	100	236	2249	80	2.3	E30613 DXA / DAC
	D3079	3/4	212	125	100	356	360	80	3.1	E30625 DXA E30625 DAC
	D3109	1	297	175	100	356	360	80	3.2	E30625 DXA / DAC

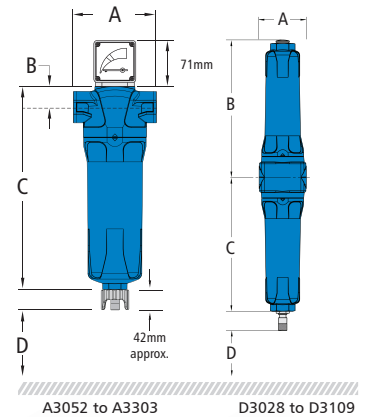
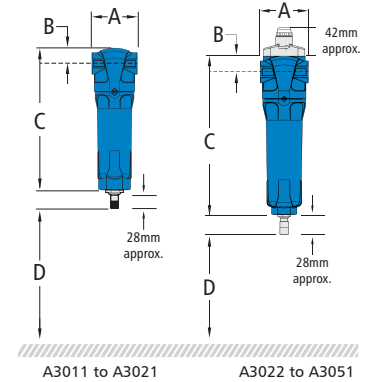
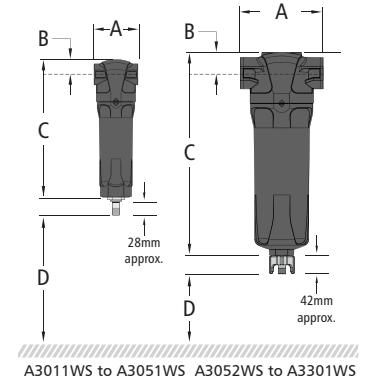

Grade	X25		X5		X1		XA		AC	
Particle removal*	25 micron		5 micron		1 micron		0.01 micron		0.01 micron	
Maximum particle size class to ISO 8573-1: 2010.	-		3		2		1		1	
Maximum oil content	-		4		2		1		1	
Maximum oil carryover at 20°C (68°F)	10 mg/m ³		5 mg/m ³		0.1 mg/m ³		0.01 mg/m ³		0.003 mg/m ³	
Pressure loss - clean & dry	30 mbar	0.4 psi	40 mbar	0.6 psi	55 mbar	0.8 psi	85 mbar	1.2 psi	115 mbar	1.7 psi
Pressure loss - saturated	50 mbar	0.7 psi	75 mbar	1.1 psi	125 mbar	1.8 psi	125 mbar	1.8 psi	N/A	N/A
Pressure loss - element change	12 mths	8000 hrs	12 mths	8000 hrs	12 mths	8000 hrs	12 mths	8000 hrs	6 mths	1000 hrs
Maximum temperature**	120°C 248°F		120°C 248°F		120°C 248°F		120°C 248°F		50°C** 122°F**	
Maximum working pressure	16 barg	232 psig	16 barg	232 psig	16 barg	232 psig	16 barg	232 psig	16 barg	232 psig
Element end cap colour	Black		Green		Red		Blue		Black	

* Particulate filtration grades RX25 (25 micron), RX5 (5 micron), RX1 (1 micron), RXA (0.01 micron), RAC (Activated Carbon) are also available.
 ** Recommended operating temperature 25°C (77°F)

Pressure correction factors										
For maximum flow rate, multiply model flow rate by the correction factor corresponding to the minimum operating pressure										
Operating pressure barg (psig)	4 (58)	5 (72)	6 (87)	7 (100)	8 (115)	10 (145)	12 (174)	14 (203)	16 (232)	20 (290)
7 barg - correction factor	0.76	0.84	0.92	1.00	1.07	1.19	1.31	1.41	1.51	1.6



THE QUEEN'S AWARDS
FOR ENTERPRISE:
INNOVATION
2016



THE QUEEN'S AWARDS
FOR ENTERPRISE:
INTERNATIONAL TRADE
2012



W WALKER FILTRATION

The ultimate filtration & drying technology

Walker Filtration Ltd

Birtley Road, Washington,
Tyne & Wear, NE38 9DA, UK

tel +44 (0) 191 417 7816

fax +44 (0) 191 415 3748

email sales@walkerfiltration.co.uk

web www.walkerfiltration.com

Walker Filtration Inc.

4748 Pacific Avenue
Erie, PA 16506, USA

tel +1 814 836 2900

fax +1 814 836 7921

email usa@walkerfiltration.com

web www.walkerfiltration.com

Walker Filtration Pty Ltd

16-18 Lindon Court,
Tullamarine VIC 3043, Australia

tel +61 (0)3 9330 4144

fax +61 (0)3 9330 4177

email sales@walkerfiltration.com.au

web www.walkerfiltration.com.au

Walker Filtration Ltd Japan

Hulic Gaienmae Building, 2nd Floor
2-7-26 KitaAoyama, Minatoku

Tokyo, 107-0061, Japan

tel +81 (0)3 6890 6911

fax +81 (0)3 6685 2974

email japan@walkerfiltration.com

web www.walkerfiltration.com