

The ultimate filtration & drying technology

Compressed Air Threaded Filters



A comprehensive range of threaded filters with 19 models offering connections from 1/4" to 3" and capacities up to 2550 Nm³/h (1500 SCFM).

Optimised modular housing design ensures high performance, ease of installation and multiple close coupling. Manufactured in cast aluminium alloy with Walker E-coat protection for a robust and corrosion resistant product.

Custom engineered media for optimised performance & efficiency

Oleophobic borosilicate media and a custom engineered anti re-entrainment layer guarantees exceptional dirt holding and drainage. Unique material construction minimises pressure drop and improves energy efficiency.

Self centralising, drop-fit, anti-vibration, colour coded elements

A unique endcap design which engages with the bowl, prevents vibration, improves stability and assists drainage. Colour coded elements make grade identification swift and simple.

Intelligent, unique, modular filter housing design



www.walkerfiltration.com

Applications include

- Chemical
- Dental
- Electronics
- Emissions Monitoring
- Food & Beverage
- Instrumentation
- Laboratories
- Laser Cutting
- Manufacturing
- Military
- Oil & Gas
- Paint Applications
- Pharmaceutical Manufacturing
- Pneumatic Conveying
- Railway



THE QUEEN'S AWARDS
FOR ENTERPRISE:
INTERNATIONAL TRADE
2012



WALKER
FILTRATION



Technical Specification

filter model	pipe size	flow rate*		dimensions (mm)				weight Kg	element model
		Nm ³ /h	SCFM	A	B	C	D		
A018 (grade)	¼	13.6	8	50	18	152	60	0.3	E0304 (grade)
A019 (grade)	¼	25.5	15	50	18	152	60	0.3	E0305 (grade)
A028 (grade)	¼	42.5	25	70	65	231	70	0.6	E0406 (grade)
A038 (grade)	⅜	59.5	35	70	65	231	70	0.6	E0407 (grade)
A058 (grade)	½	85	50	70	65	272	70	0.7	E0413 (grade)
A059 (grade)	½	119	70	100	105	346	80	1.6	E0613 (grade)
A078 (grade)	¾	144	85	100	105	346	80	1.6	E0613 (grade)
A079 (grade)	¾	212	125	100	105	466	80	2.0	E0620 (grade)
A108 (grade)	1	229	135	100	105	466	80	2.0	E0620 (grade)
A109 (grade)	1	297	175	100	105	466	80	2.0	E0625 (grade)
A128 (grade)	1¼	476	280	122	112	530	80	2.8	E0730 (grade)
A158 (grade)	1½	545	320	122	112	530	80	2.8	E0730 (grade)
A159 (grade)	1½	680	400	146	122	552	100	4.2	E0830 (grade)
A208 (grade)	2	765	450	146	122	552	100	4.2	E0830 (grade)
A209 (grade)	2	1190	700	146	122	855	100	6.3	E0860 (grade)
A254 (grade)	2½	1445	850	210	137	665	100	8.5	E1140 (grade)
A340 (grade)	3	1530	900	210	137	665	100	8.5	E1140 (grade)
A360 (grade)	3	2125	1250	210	137	885	100	10.5	E1160 (grade)
A390 (grade)	3	2550	1500	210	137	1045	100	12.0	E1175 (grade)

* Rated flow at 7 barg, reference conditions 1 bar (a) 20°C

	X25		X5		X1		XA		AC	
Particle removal	25 micron		5 micron		1 micron		0.01 micron		0.01 micron	
Maximum particle size class**	-		3		2		1		1	
Maximum oil content	-		4		2		1		1	
Maximum oil carryover at 20°C (68°F)	10 mg/m ³		5 mg/m ³		0.1 mg/m ³		0.01 mg/m ³		0.003 mg/m ³	
Pressure loss: clean and dry	30 mbar	0.4 psi	40 mbar	0.6 psi	75 mbar	1.1 psi	100 mbar	1.5 psi	75 mbar	1.1 psi
Pressure loss: saturated	50 mbar	0.7 psi	75 mbar	1.1 psi	150 mbar	2.2 psi	300 mbar	4.4 psi	-	
Pressure loss: element change	400 mbar	6 psi	400 mbar	6 psi	400 mbar	6 psi	400 mbar	6 psi	6 months	1000 hours
Maximum temperature	120°C	248°F	120°C	248°F	120°C	248°F	120°C	248°F	25°C	77°F
Maximum working pressure	16 barg	232 psig	16 barg	232 psig	16 barg	232 psig	16 barg	232 psig	16 barg	232 psig
Element end cap colour	black		green		red		blue		black	

** to ISO 8573-1:2010 (E)

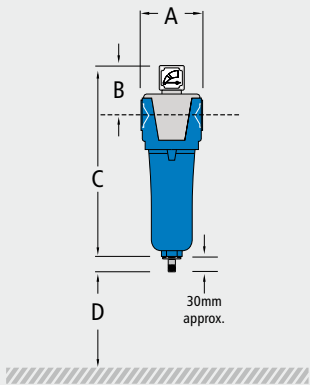

A018 (grade) to A390 (grade)

pressure correction factors

for maximum flow rate, multiply model flow rate by the correction factor corresponding to the minimum operating pressure

Operating pressure barg (psig)	4 (58)	5 (72)	6 (87)	7 (100)	8 (115)	10 (145)	12 (174)	14 (203)	16 (232)
7 barg - correction factor	0.76	0.84	0.92	1.00	1.07	1.19	1.31	1.41	1.51

technical notes

- Direction of air flow is inside to out through the filter element.
- Pop up indicators (65DPUG) are fitted to models A028 to A058 as standard. Differential pressure indicators (65DPiG) are fitted to models A059 to A390 as standard. AC grade filters do not include DP equipment.
- Threaded filters are fitted with float operated automatic drain valves. DVAS16C on models A018 to A058 and DVAS16 on models A059 to A390. Models A059 to A390 can be adapted to use ¼" drains with a reducer.
- Activated carbon filters must not operate in oil saturated conditions and will not remove certain types of gases including carbon monoxide (CO) and carbon dioxide (CO₂).
- Threaded filters are manufactured from cast aluminium alloy and are PED 97/23/EC compliant for group 2 gases.
- Threaded connections are Rp (BSP parallel) to ISO 7/1 or NPT to ANSI B2.1 if supplied within North America.
- For NPT connections, add the suffix N e.g. A018WSN.
- Filter elements should be changed every 12 months / 8000 hours (whichever comes first). Activated carbon filter elements should be changed every 6 months / 1000 hours (whichever comes first).
- Filters are suitable for use with mineral and synthetic oils plus oil-free compressed air applications.